

**OPA2541**

## Dual High Power OPERATIONAL AMPLIFIER

### FEATURES

- OUTPUT CURRENTS TO 5A
- POWER SUPPLIES TO  $\pm 40V$
- FET INPUT
- ELECTRICALLY ISOLATED CASE

### APPLICATIONS

- MOTOR DRIVER
- SERVO AMPLIFIER
- SYNCRO/RESOLVER EXCITATION
- VOICE COIL DRIVER
- BRIDGE AMPLIFIER
- PROGRAMMABLE POWER SUPPLY
- AUDIO AMPLIFIER

### DESCRIPTION

The OPA2541 is a dual power operational amplifier capable of operation from power supplies up to  $\pm 40V$  and output currents of 5A continuous. With two monolithic power amplifiers in a single package it provides unequalled functional density.

The industry-standard 8-pin TO-3 package is isolated from all internal circuitry allowing it to be mounted directly to a heat sink without insulators which degrade thermal performance. Internal circuitry limits output current to approximately 6A.

The OPA2541 is available in both industrial and military temperature range versions.

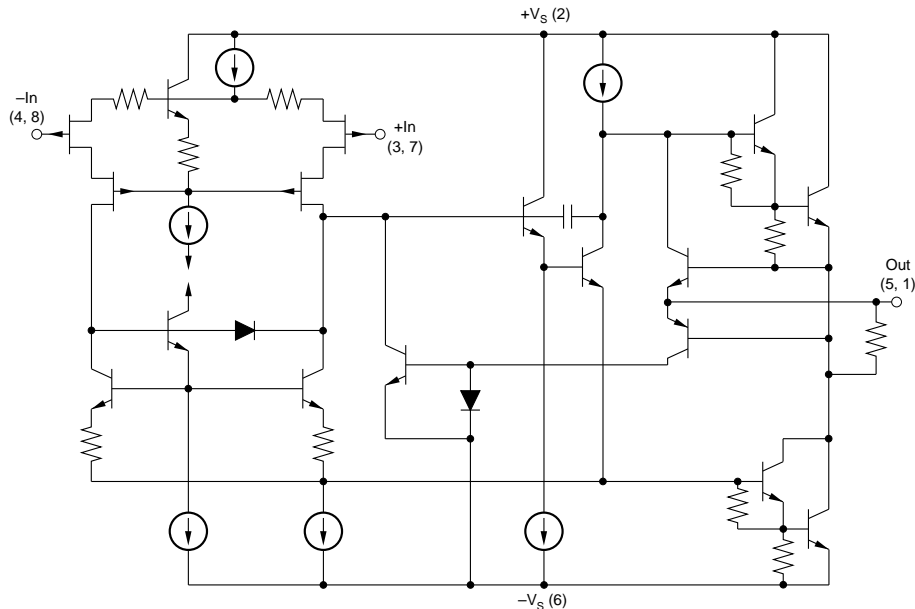

International Airport Industrial Park • Mailing Address: PO Box 11400 • Tucson, AZ 85734 • Street Address: 6730 S. Tucson Blvd. • Tucson, AZ 85706  
Tel: (520) 746-1111 • Twx: 910-952-1111 • Cable: BBRCORP • Telex: 066-6491 • FAX: (520) 889-1510 • Immediate Product Info: (800) 548-6132

# SPECIFICATIONS

## ELECTRICAL

At  $T_C = +25^\circ\text{C}$  and  $V_S = \pm 35\text{VDC}$ , unless otherwise noted.

PARAMETER	CONDITIONS	OPA2541AM			OPA2541BM, SM			UNITS
		MIN	TYP	MAX	MIN	TYP	MAX	
<b>INPUT OFFSET VOLTAGE</b>								
$V_{OS}$ vs Temperature vs Supply Voltage vs Power	Specified Temperature Range $V_S = \pm 10\text{V to } \pm V_{MAX}$		$\pm 2$ $\pm 20$ $\pm 2.5$ $\pm 20$	$\pm 10$ $\pm 40$ $\pm 10$ $\pm 60$		$\pm 0.25$ $\pm 15$ * *	$\pm 1$ $\pm 30$ * *	mV $\mu\text{V}/^\circ\text{C}$ $\mu\text{V}/\text{V}$ $\mu\text{V}/\text{W}$
<b>INPUT BIAS CURRENT</b>								
$I_B$	Specified Temperature Range		15 Note 1	50		*	*	pA
<b>INPUT OFFSET CURRENT</b>								
$I_{OS}$	Specified Temperature Range		$\pm 5$ Note 1	$\pm 30$		*	*	pA
<b>INPUT CHARACTERISTICS</b>								
Common-Mode Voltage Range Common-Mode Rejection Input Capacitance Input Impedance, DC	Specified Temperature Range $V_{CM} = (\pm V_S) - 6\text{V}$	$\pm( V_S  - 6)$ 95	$\pm( V_S  - 3)$ 106 5 1		*	*		V dB pF $10^{12}\Omega$
<b>GAIN CHARACTERISTICS</b>								
Open Loop Gain at 10Hz Gain-Bandwidth Product	$R_L = 6\Omega$	90	96 1.6		*	*		dB MHz
<b>OUTPUT</b>								
Voltage Swing  Current, Continuous	$I_O = 5\text{A}$ $I_O = 2\text{A}$ $I_O = 0.5\text{A}$ +25°C +85°C +125°C (SM grade only)	$\pm( V_S  - 5.5)$ $\pm( V_S  - 4.5)$ $\pm( V_S  - 4)$ 5 4	$\pm( V_S  - 4.5)$ $\pm( V_S  - 3.6)$ $\pm( V_S  - 3.2)$ 7.0 5.0		*	*		V V V A A A
<b>AC PERFORMANCE</b>								
Slew Rate Power Bandwidth Settling Time to 0.1%  Capacitive Load  Phase Margin Channel Separation	$R_L = 8\Omega$ , $V_O = 20\text{Vrms}$ 2V Step  Specified Temperature Range, $G = 1$ Specified Temperature Range, $G > 10$ Specified Temperature Range, $R_L = 8\Omega$ 1kHz, $R_L = 6\Omega$	6 45   40 80	8 55 2  40 80	3.3 SOA	*	*	*	V/ $\mu\text{s}$ kHz $\mu\text{s}$ nF Degrees dB
<b>POWER SUPPLY</b>								
Power Supply Voltage, $\pm V_S$ Current, Quiescent	Specified Temperature Range Total—Both Amplifiers	$\pm 10$	$\pm 30$ 40	$\pm 35$ 50	*	$\pm 35$ *	$\pm 40$ *	V mA
<b>THERMAL RESISTANCE</b>								
$\theta_{JC}$ , (Junction-to-Case) $\theta_{JC}$ $\theta_{JC}$ $\theta_{JC}$ $\theta_{JA}$ , (Junction-to-Ambient)	Both Amplifiers <sup>(2)</sup> , AC Output $f > 60\text{Hz}$ Both Amplifiers <sup>(2)</sup> , DC Output One Amplifier, AC Output $f > 60\text{Hz}$ One Amplifier, DC Output No Heat Sink		0.8 0.9 1.25 1.4 30	1.0 1.2 1.5 1.9		*	*	$^\circ\text{C}/\text{W}$ $^\circ\text{C}/\text{W}$ $^\circ\text{C}/\text{W}$ $^\circ\text{C}/\text{W}$ $^\circ\text{C}/\text{W}$
<b>TEMPERATURE RANGE</b>								
Case	AM, BM SM	-25		+85	*		*	$^\circ\text{C}$ $^\circ\text{C}$

\*Specification same as OPA2541AM.

NOTES: (1) Input bias and offset current approximately doubles for every 10°C increase in temperature. (2) Assumes equal dissipation in both amplifiers.

The information provided herein is believed to be reliable; however, BURR-BROWN assumes no responsibility for inaccuracies or omissions. BURR-BROWN assumes no responsibility for the use of this information, and all use of such information shall be entirely at the user's own risk. Prices and specifications are subject to change without notice. No patent rights or licenses to any of the circuits described herein are implied or granted to any third party. BURR-BROWN does not authorize or warrant any BURR-BROWN product for use in life support devices and/or systems.

## ABSOLUTE MAXIMUM RATINGS

Supply Voltage, $+V_S$ to $-V_S$ .....	80V
Output Current .....	see SOA
Power Dissipation, Internal <sup>(1)</sup> .....	125W
Input Voltage: Differential .....	$\pm V_S$
Common-mode .....	$\pm V_S$
Temperature: Pin Solder, 10s .....	+300°C
Junction <sup>(1)</sup> .....	+150°C
Temperature Range:	
Storage .....	-65°C to +150°C
Operating (Case) .....	-55°C to +125°C

NOTE: (1) Long term operation at the maximum junction temperature will result in reduced product life. Derate internal power dissipation to achieve high MTTF.

## CONNECTION DIAGRAM

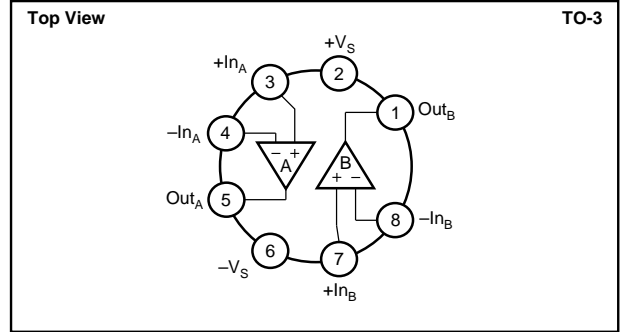

## PACKAGE INFORMATION

MODEL	PACKAGE	PACKAGE DRAWING NUMBER <sup>(1)</sup>
OPA2541AM	TO-3	030
OPA2541BM	TO-3	030
OPA2541SM	TO-3	030

NOTE: (1) For detailed drawing and dimension table, please see end of data sheet, or Appendix D of Burr-Brown IC Data Book.

## ORDERING INFORMATION

MODEL	PACKAGE	TEMPERATURE RANGE
OPA2541AM	TO-3	-25°C to +85°C
OPA2541BM	TO-3	-25°C to +85°C
OPA2541SM	TO-3	-55°C to +125°C

## TYPICAL PERFORMANCE CURVES

$T_A = +25^\circ\text{C}$  and  $V_S = \pm 35\text{VDC}$ , unless otherwise noted.

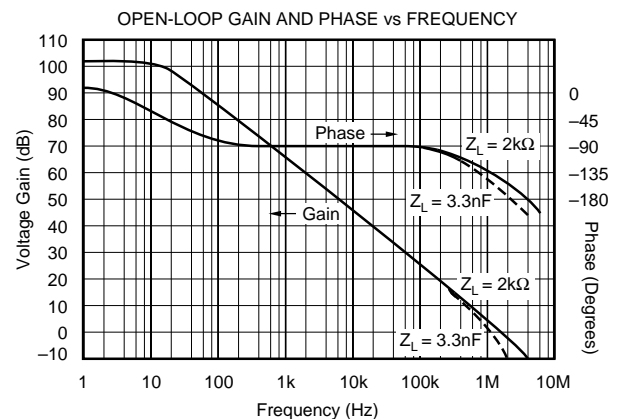
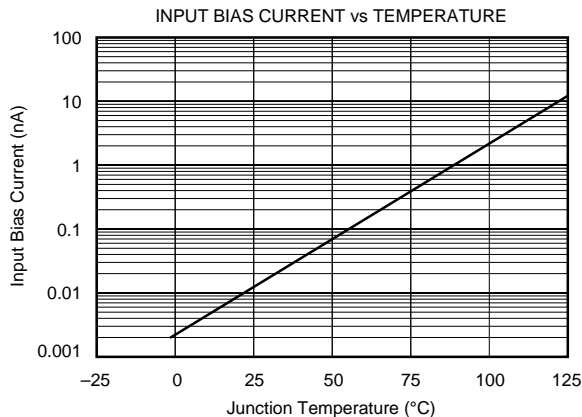

# TYPICAL PERFORMANCE CURVES (CONT)

$T_A = +25^\circ\text{C}$  and  $V_S = \pm 35\text{VDC}$ , unless otherwise noted.

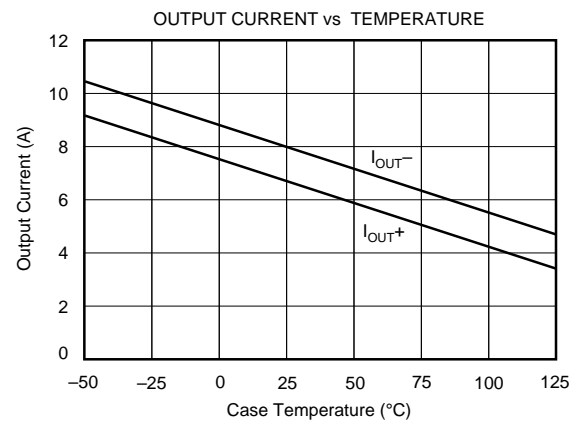
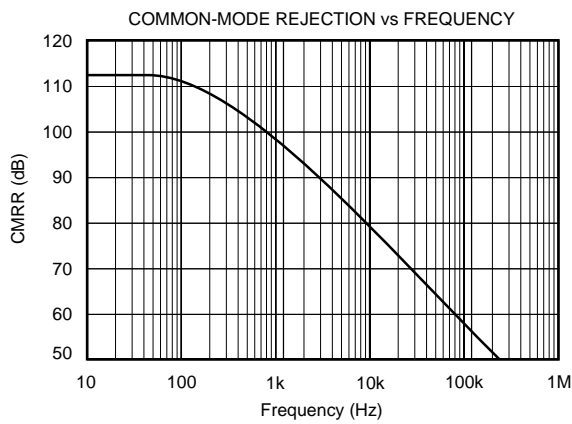
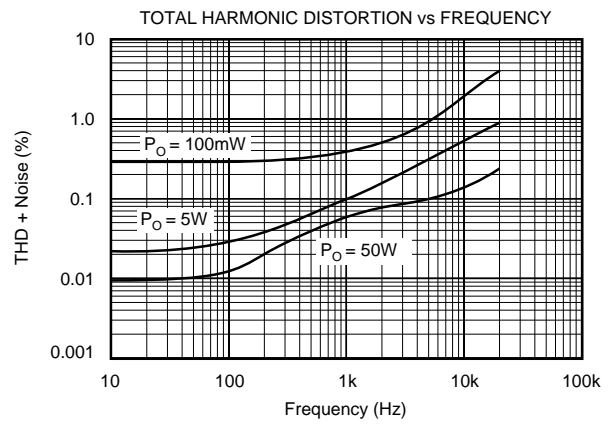
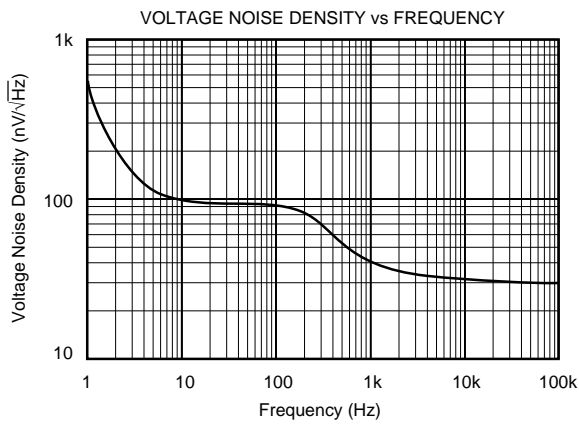
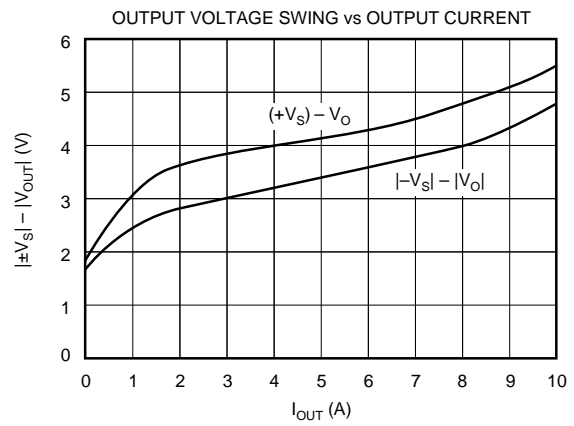
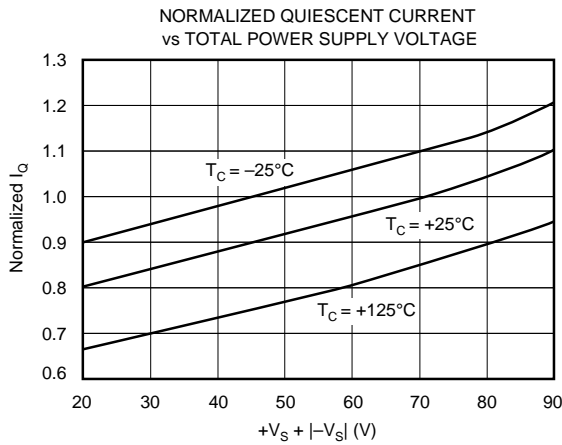

# TYPICAL PERFORMANCE CURVES (CONT)

$T_A = +25^\circ\text{C}$  and  $V_S = \pm 35\text{VDC}$ , unless otherwise noted.

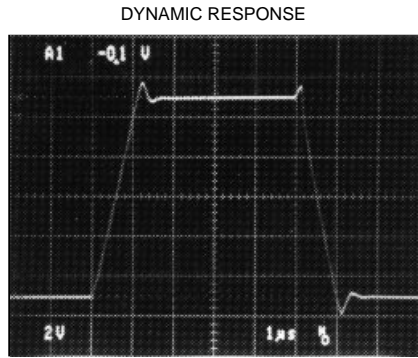

$Z_{\text{LOAD}} = \infty$ ,  $V_S = \pm 35\text{V}$ ,  $A_V = +1$

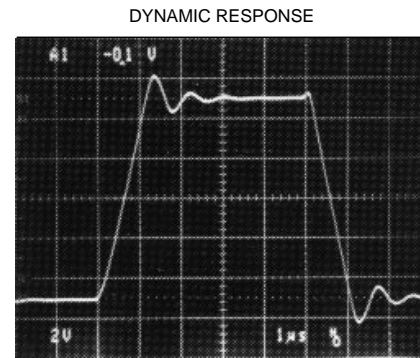

$Z_{\text{LOAD}} = 4700\text{pF}$ ,  $V_S = \pm 35\text{V}$ ,  $A_V = +1$

## INSTALLATION INSTRUCTIONS

### POWER SUPPLIES

The OPA2541 is specified for operation from power supplies up to  $\pm 40\text{V}$ . It can also be operated from an unbalanced or a single power supply so long as the total power supply voltage does not exceed  $80\text{V}$  ( $70\text{V}$  for “AM” grade). The power supplies should be bypassed with low series impedance capacitors such as ceramic or tantalum. These should be located as near as practical to the amplifier’s power supply pins. Good power amplifier circuit layout is, in general, like good high-frequency layout. Consider the path of large power supply and output currents. Avoid routing these connections near low-level input circuitry to avoid waveform distortion and instability.

Signal dependent load current can modulate the power supply voltage with inadequate power supply bypassing. This can affect both amplifiers’ outputs. Since the second amplifier’s signal may not be related to the first, this will degrade the inherent channel separation of the OPA2541.

### HEAT SINKING

Most applications will require a heat sink to prevent junction temperatures from exceeding the  $150^\circ\text{C}$  maximum rating. The type of heat sink required will depend on the output signals, power dissipation of each amplifier, and ambient temperature. The thermal resistance from junction-to-case,  $\theta_{\text{JC}}$ , depends on how the power dissipation is distributed on the amplifier die.

DC output concentrates the power dissipation in one output transistor. AC output distributes the power dissipation equally between the two output transistors and therefore has lower thermal resistance. Similarly, the power dissipation may be all in one amplifier (worst case) or equally distributed between the two amplifiers (best case). Thermal resistances are provided for each of these possibilities. The case-to-junction temperature rise is the product of the power dissi-

pation (total of both amplifiers) times the appropriate thermal resistance—

$$\Delta T_{\text{JC}} = (P_{\text{D total}}) (\theta_{\text{JC}}).$$

Sufficient heat sinking must be provided to keep the case temperature within safe limits for the maximum ambient temperature and power dissipation. The thermal resistance of the heat sink required may be calculated by:

$$\theta_{\text{HS}} = (150^\circ\text{C} - \Delta T_{\text{JC}} - T_A) / P_{\text{D}}.$$

Commercially available heat sinks usually specify thermal resistance. These ratings are often suspect, however, since they depend greatly on the mounting environment and air flow conditions. Actual thermal performance should be verified by measurement of case temperature under the required load and environmental conditions.

No insulating hardware is required when using the OPA2541. Since mica and other similar insulators typically add  $0.7^\circ\text{C}/\text{W}$  thermal resistance, this is a significant advantage. See Burr-Brown Application Note AN-83 for further details on heat sinking.

### SAFE OPERATING AREA

The Safe Operating Area (SOA) curve provides comprehensive information on the power handling abilities of the OPA2541. It shows the allowable output current as a function of the voltage across the conducting output transistor (see Figure 1). This voltage is equal to the power supply voltage minus the output voltage. For example, as the amplifier output swings near the positive power supply voltage, the voltage across the output transistor decreases and the device can safely provide large output currents demanded by the load.

The internal current limit will not provide short-circuit protection in most applications. When the amplifier output is shorted to ground, the full power supply voltage is impressed across the conducting output transistor. For instance, with  $V_s = \pm 35V$ , a short circuit to ground would impress 35V across the conducting power transistor. The maximum safe output current at this voltage is 1.8A, so the internal current limit would not protect the amplifier. The unit-to-unit variation and temperature dependence of the internal current limit suggest that it be used to handle abnormal conditions and not activated in commonly encountered circuit operation.

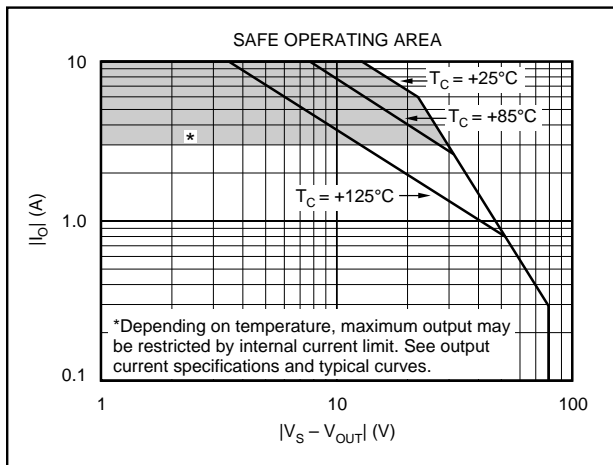

FIGURE 1. Safe Operating Area.

Reactive, or EMF generating loads such as DC motors can present demanding SOA requirements. With a purely reactive load, output voltage current occurs when the output voltage is zero and the voltage across the conducting transistor is equal to the full power supply voltage. See Burr-Brown Application Note AN-123 for further information on evaluating SOA.

Applications with inductive or EMF-generating loads which can produce "kick back" voltage surges to the amplifiers should include clamp diodes from the output terminals to the power supplies. These diodes should be chosen to limit the peak amplifier output voltage surges to less than 2V beyond the power supply rail voltage. Common 1A rated rectifier diodes will suffice in most applications.

## APPLICATIONS CIRCUITS

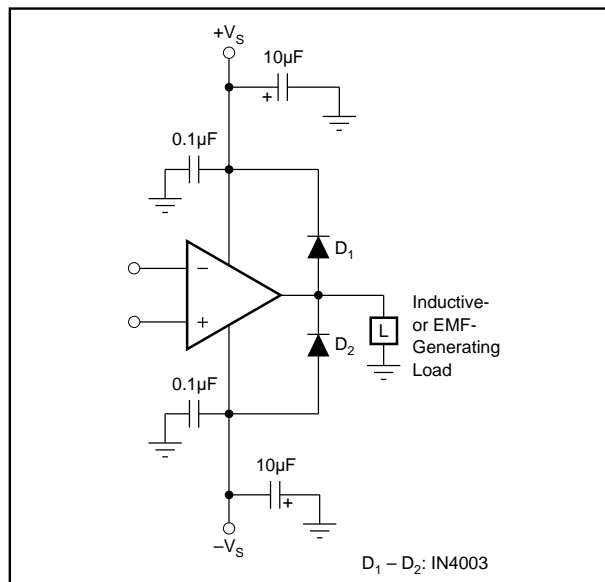

FIGURE 2. Clamping Output for EMF-Generating Loads.

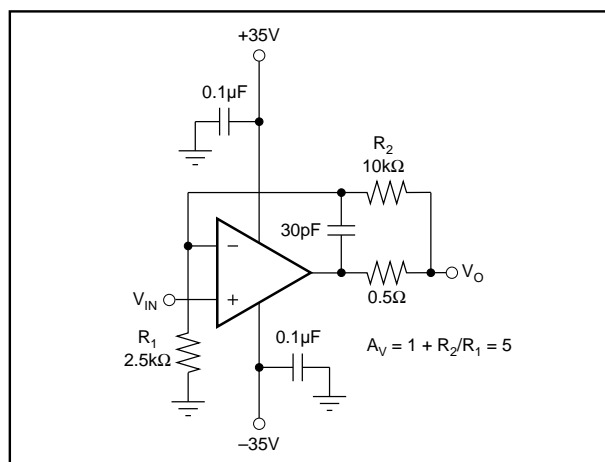

FIGURE 3. Isolating Capacitive Loads.

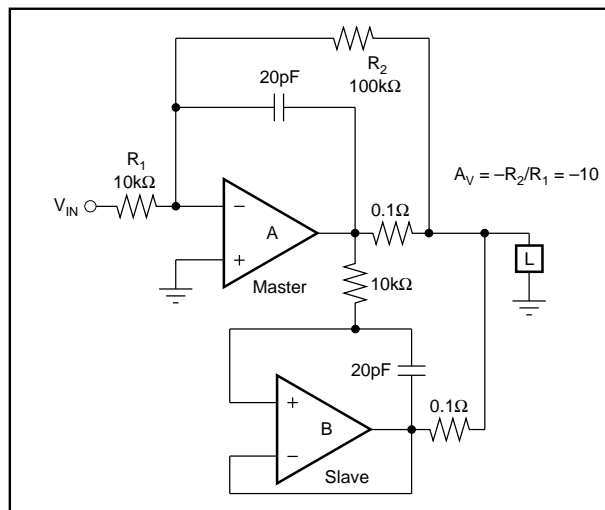

FIGURE 4. Paralleled Operation, Extended SOA.

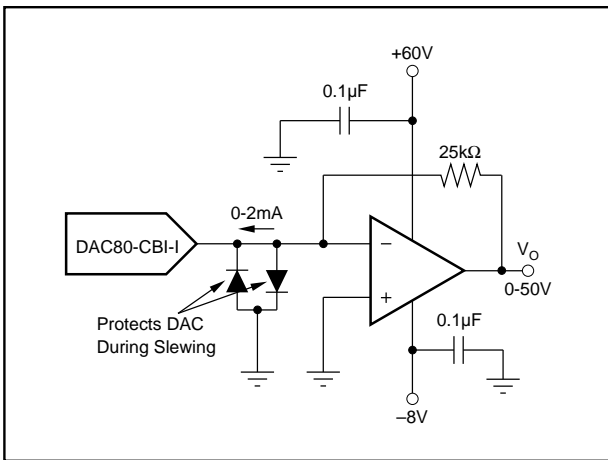

FIGURE 5. Programmable Voltage Source.

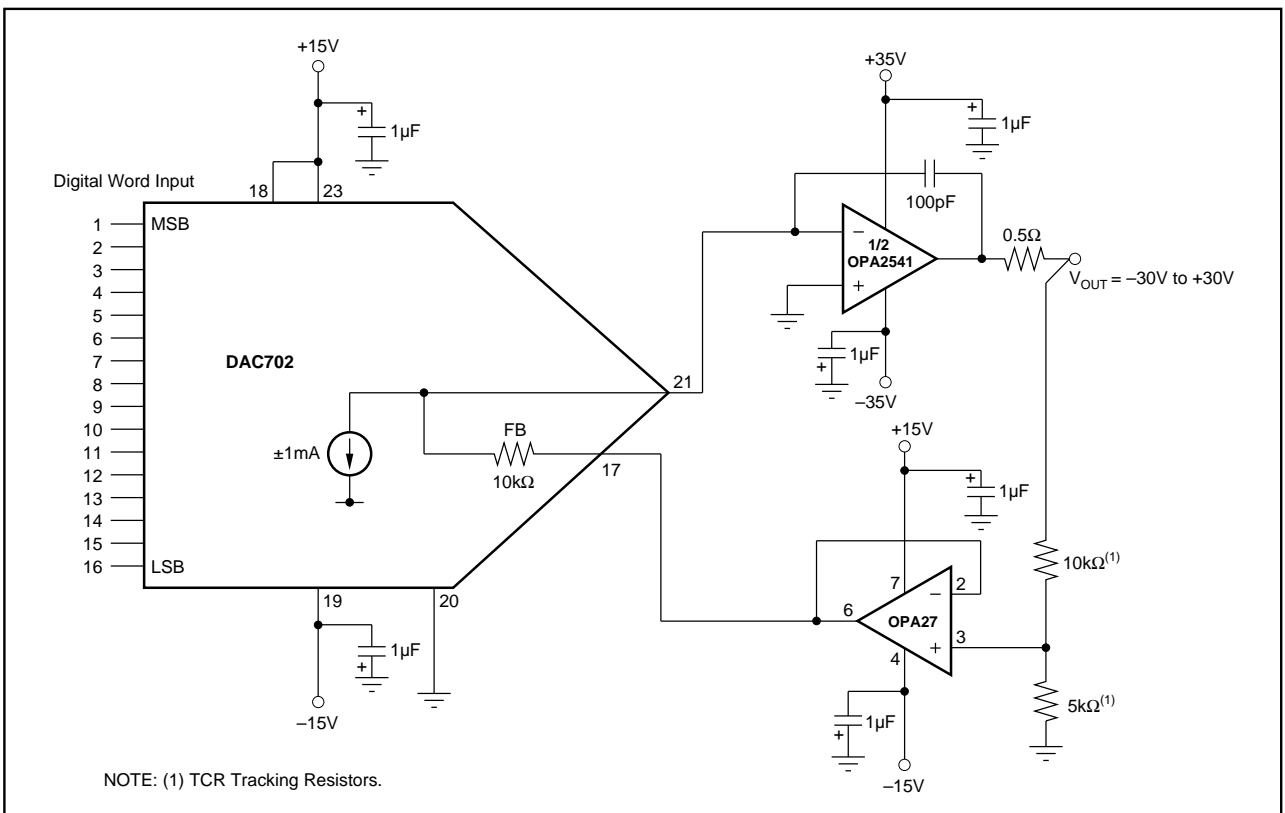

FIGURE 6. 16-Bit Programmable Voltage Source.

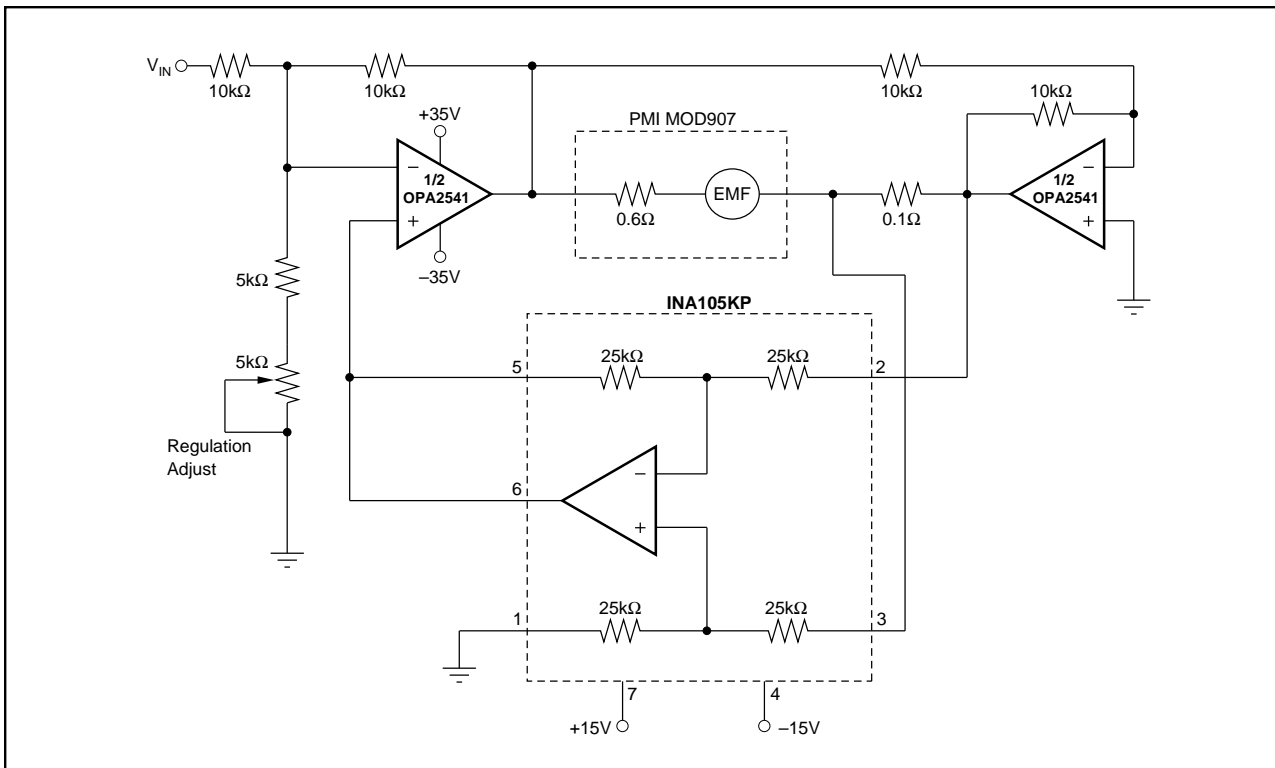

FIGURE 7. Bridge Amplifier Motor-Speed Controller.

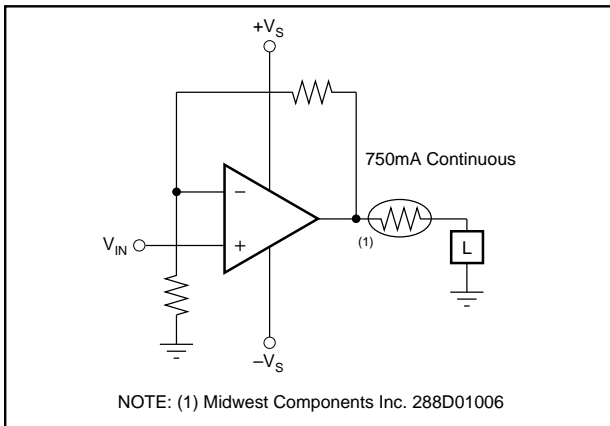

FIGURE 8. Limiting Output Current.



**PACKAGING INFORMATION**

Orderable Device	Status <sup>(1)</sup>	Package Type	Package Drawing	Pins	Package Qty	Eco Plan <sup>(2)</sup>	Lead/Ball Finish	MSL Peak Temp <sup>(3)</sup>
OPA2541AM	NRND	TO-3	LMF	8	18	Pb-Free (RoHS Exempt)	Call TI	N / A for Pkg Type
OPA2541AM-BI	NRND	ZZ (BB)	ZZ030	8		TBD	Call TI	Call TI
OPA2541BM	NRND	TO-3	LMF	8	18	Pb-Free (RoHS Exempt)	Call TI	N / A for Pkg Type
OPA2541SM	NRND	TO-3	LMF	8	18	Pb-Free (RoHS Exempt)	Call TI	N / A for Pkg Type
OPA2541SMQ	NRND	TO-3	LMF	8	18	Pb-Free (RoHS Exempt)	Call TI	N / A for Pkg Type

<sup>(1)</sup> The marketing status values are defined as follows:

**ACTIVE:** Product device recommended for new designs.

**LIFEBUY:** TI has announced that the device will be discontinued, and a lifetime-buy period is in effect.

**NRND:** Not recommended for new designs. Device is in production to support existing customers, but TI does not recommend using this part in a new design.

**PREVIEW:** Device has been announced but is not in production. Samples may or may not be available.

**OBSOLETE:** TI has discontinued the production of the device.

<sup>(2)</sup> Eco Plan - The planned eco-friendly classification: Pb-Free (RoHS), Pb-Free (RoHS Exempt), or Green (RoHS & no Sb/Br) - please check <http://www.ti.com/productcontent> for the latest availability information and additional product content details.

**TBD:** The Pb-Free/Green conversion plan has not been defined.

**Pb-Free (RoHS):** TI's terms "Lead-Free" or "Pb-Free" mean semiconductor products that are compatible with the current RoHS requirements for all 6 substances, including the requirement that lead not exceed 0.1% by weight in homogeneous materials. Where designed to be soldered at high temperatures, TI Pb-Free products are suitable for use in specified lead-free processes.

**Pb-Free (RoHS Exempt):** This component has a RoHS exemption for either 1) lead-based flip-chip solder bumps used between the die and package, or 2) lead-based die adhesive used between the die and leadframe. The component is otherwise considered Pb-Free (RoHS compatible) as defined above.

**Green (RoHS & no Sb/Br):** TI defines "Green" to mean Pb-Free (RoHS compatible), and free of Bromine (Br) and Antimony (Sb) based flame retardants (Br or Sb do not exceed 0.1% by weight in homogeneous material)

<sup>(3)</sup> MSL, Peak Temp. -- The Moisture Sensitivity Level rating according to the JEDEC industry standard classifications, and peak solder temperature.

**Important Information and Disclaimer:**The information provided on this page represents TI's knowledge and belief as of the date that it is provided. TI bases its knowledge and belief on information provided by third parties, and makes no representation or warranty as to the accuracy of such information. Efforts are underway to better integrate information from third parties. TI has taken and continues to take reasonable steps to provide representative and accurate information but may not have conducted destructive testing or chemical analysis on incoming materials and chemicals. TI and TI suppliers consider certain information to be proprietary, and thus CAS numbers and other limited information may not be available for release.

In no event shall TI's liability arising out of such information exceed the total purchase price of the TI part(s) at issue in this document sold by TI to Customer on an annual basis.

## IMPORTANT NOTICE

Texas Instruments Incorporated and its subsidiaries (TI) reserve the right to make corrections, modifications, enhancements, improvements, and other changes to its products and services at any time and to discontinue any product or service without notice. Customers should obtain the latest relevant information before placing orders and should verify that such information is current and complete. All products are sold subject to TI's terms and conditions of sale supplied at the time of order acknowledgment.

TI warrants performance of its hardware products to the specifications applicable at the time of sale in accordance with TI's standard warranty. Testing and other quality control techniques are used to the extent TI deems necessary to support this warranty. Except where mandated by government requirements, testing of all parameters of each product is not necessarily performed.

TI assumes no liability for applications assistance or customer product design. Customers are responsible for their products and applications using TI components. To minimize the risks associated with customer products and applications, customers should provide adequate design and operating safeguards.

TI does not warrant or represent that any license, either express or implied, is granted under any TI patent right, copyright, mask work right, or other TI intellectual property right relating to any combination, machine, or process in which TI products or services are used. Information published by TI regarding third-party products or services does not constitute a license from TI to use such products or services or a warranty or endorsement thereof. Use of such information may require a license from a third party under the patents or other intellectual property of the third party, or a license from TI under the patents or other intellectual property of TI.

Reproduction of TI information in TI data books or data sheets is permissible only if reproduction is without alteration and is accompanied by all associated warranties, conditions, limitations, and notices. Reproduction of this information with alteration is an unfair and deceptive business practice. TI is not responsible or liable for such altered documentation. Information of third parties may be subject to additional restrictions.

Resale of TI products or services with statements different from or beyond the parameters stated by TI for that product or service voids all express and any implied warranties for the associated TI product or service and is an unfair and deceptive business practice. TI is not responsible or liable for any such statements.

TI products are not authorized for use in safety-critical applications (such as life support) where a failure of the TI product would reasonably be expected to cause severe personal injury or death, unless officers of the parties have executed an agreement specifically governing such use. Buyers represent that they have all necessary expertise in the safety and regulatory ramifications of their applications, and acknowledge and agree that they are solely responsible for all legal, regulatory and safety-related requirements concerning their products and any use of TI products in such safety-critical applications, notwithstanding any applications-related information or support that may be provided by TI. Further, Buyers must fully indemnify TI and its representatives against any damages arising out of the use of TI products in such safety-critical applications.

TI products are neither designed nor intended for use in military/aerospace applications or environments unless the TI products are specifically designated by TI as military-grade or "enhanced plastic." Only products designated by TI as military-grade meet military specifications. Buyers acknowledge and agree that any such use of TI products which TI has not designated as military-grade is solely at the Buyer's risk, and that they are solely responsible for compliance with all legal and regulatory requirements in connection with such use.

TI products are neither designed nor intended for use in automotive applications or environments unless the specific TI products are designated by TI as compliant with ISO/TS 16949 requirements. Buyers acknowledge and agree that, if they use any non-designated products in automotive applications, TI will not be responsible for any failure to meet such requirements.

Following are URLs where you can obtain information on other Texas Instruments products and application solutions:

<b>Products</b>		<b>Applications</b>	
Amplifiers	<a href="http://amplifier.ti.com">amplifier.ti.com</a>	Audio	<a href="http://www.ti.com/audio">www.ti.com/audio</a>
Data Converters	<a href="http://dataconverter.ti.com">dataconverter.ti.com</a>	Automotive	<a href="http://www.ti.com/automotive">www.ti.com/automotive</a>
DSP	<a href="http://dsp.ti.com">dsp.ti.com</a>	Broadband	<a href="http://www.ti.com/broadband">www.ti.com/broadband</a>
Interface	<a href="http://interface.ti.com">interface.ti.com</a>	Digital Control	<a href="http://www.ti.com/digitalcontrol">www.ti.com/digitalcontrol</a>
Logic	<a href="http://logic.ti.com">logic.ti.com</a>	Military	<a href="http://www.ti.com/military">www.ti.com/military</a>
Power Mgmt	<a href="http://power.ti.com">power.ti.com</a>	Optical Networking	<a href="http://www.ti.com/opticalnetwork">www.ti.com/opticalnetwork</a>
Microcontrollers	<a href="http://microcontroller.ti.com">microcontroller.ti.com</a>	Security	<a href="http://www.ti.com/security">www.ti.com/security</a>
RFID	<a href="http://www.ti-rfid.com">www.ti-rfid.com</a>	Telephony	<a href="http://www.ti.com/telephony">www.ti.com/telephony</a>
Low Power Wireless	<a href="http://www.ti.com/lpw">www.ti.com/lpw</a>	Video & Imaging	<a href="http://www.ti.com/video">www.ti.com/video</a>
		Wireless	<a href="http://www.ti.com/wireless">www.ti.com/wireless</a>

Mailing Address: Texas Instruments, Post Office Box 655303, Dallas, Texas 75265  
Copyright © 2007, Texas Instruments Incorporated